

Step "A" - Brackets assembly

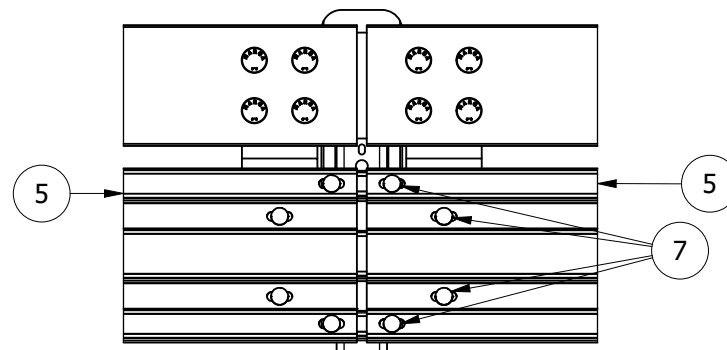

Step "B" - Corrugated splice plate & protection rail assembly

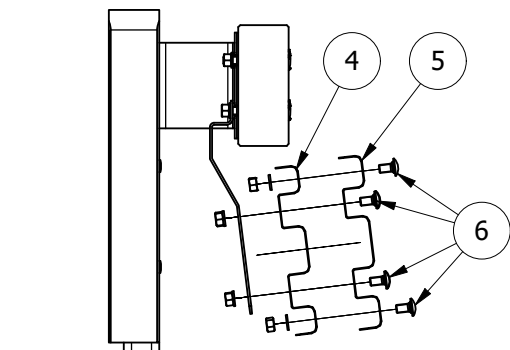
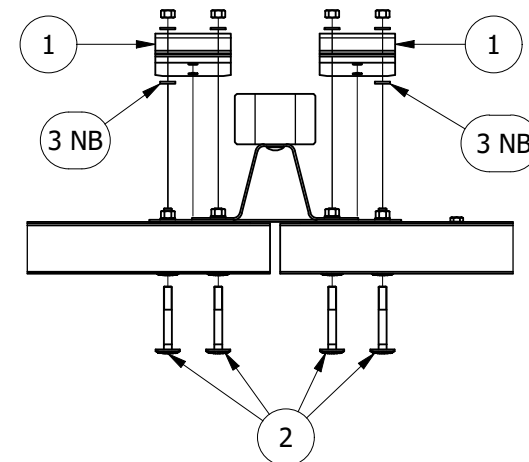
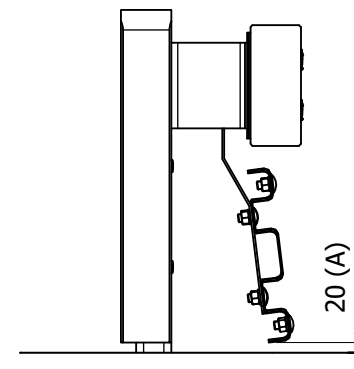

Measurements expressed in mm

Relevant measure: A= ground clearance of the lower edge of the MPS

Tightening torque: TT/TE M10x30 class 8.8 - Minimum torque 50 Nm
TT M16x30 class 8.8 - Minimum torque 50 Nm

Component list

Ref.	Item
1	Bracket
2	Bolts TTQST M16x125 class 8.8
3	Flat washer M16
4	Corrugated Splice Plate
5	Protection rail
6	Bolts TT M16x30 class 8.8



MARGARITELLI
ROAD SAFETY

Drawing
IM 005-01 MR

Review
00

Issued
04/07/2022

Date
--/--/----

Object: Road Side Safety Barrier N2BL-01
Certificate of Costancy of Performance CE n° 0497/CPR/3151
with continuous motorcyclist protection system MotoRail
Assembly instructions